

New Build - Acoustic Batten Under Floor Heating Solution

InstaCoustic acoustic batten floor system incorporating Terrain UFH tacker panel system

- A. InstaCoustic B40 Acoustic batten floor system with Terrain tacker panel UFH system
- B. 150mm (min) precast concrete floor plank - 300 kg/m² (min) mass per unit area
- C. InstaCoustic AC90/1 metal ceiling system incorporating acoustic hangers with 100mm (min) void

B40 Acoustic batten floor with Terrain 35/15-18 Tacker Panel UFH system

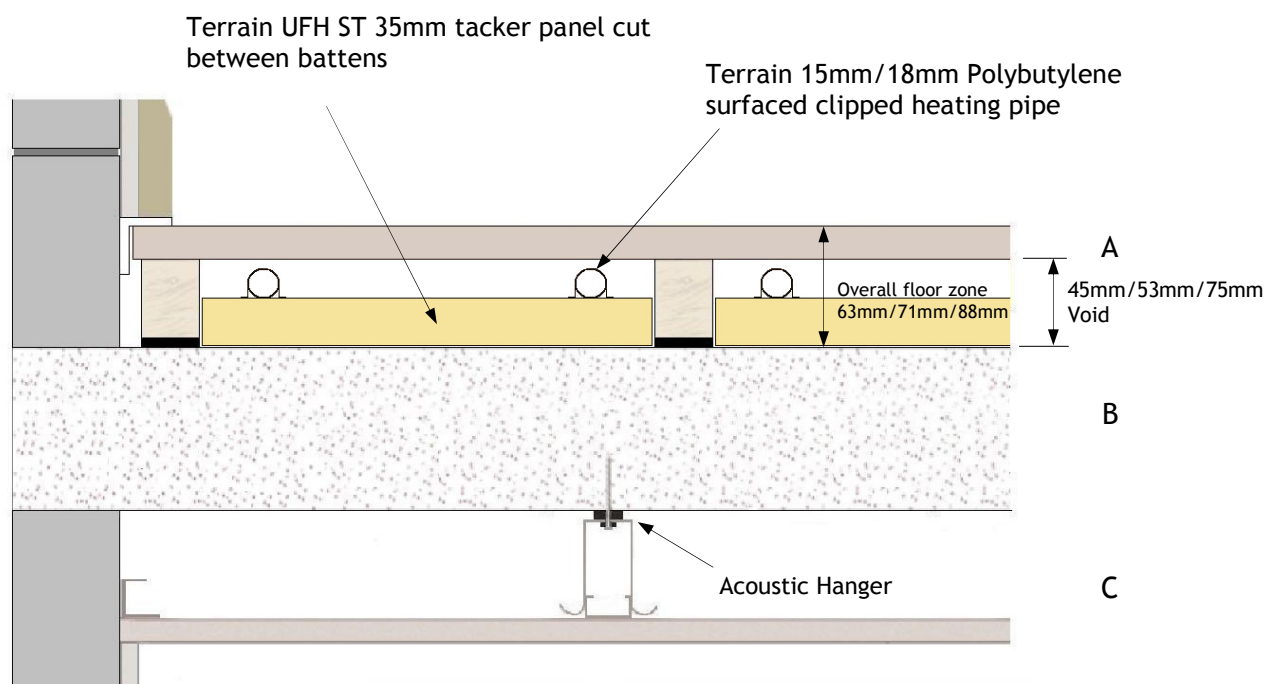

Field Sound Test Report

Results	Achieved On Site	ADE Regulations
Airborne	56 dB $D_nT_w + C_{tr}$	45 dB $D_nT_w + C_{tr}$
Impact	42 dB L_nT_w	62 dB L_nT_w

Airborne - 11dB better than regulations Impact - 20dB better than regulations

Key Issues

- Resilient flanking strip must be applied around perimeter of floor to seal and isolate from structure
- System suitable for level concrete structural floors - BS8204 Part 1 SR1 standard
- Pipes in services must not come into contact with the timber battens or overlay board, this would cause a direct transmission path
- To reduce the risk of flanking problems avoid block densities lower than 1600 kg/m³ in the wall structure
- Ceiling to be fitted before the dry-lining on the walls to improve performance
- If dot & dab is used, the centres of the dabs must be in accordance with the regulations
- Caution is required concerning floor finishes to ensure that heat transfer is not inhibited (further information and advice can be given on request)
- UFH Manifold location and space requirement to be considered and agreed
- UFH system must be installed by an approved Terrain installer

New Build - Acoustic Batten Under Floor Heating Solution

Design to be in accordance with BS EN 1263 Pt. 1-3 and covered by the relevant designers professional indemnity insurance.

Terrain approved installer to carry out works and in accordance with BS EN1264: Pt. 4 where appropriate.

1. Installation / System

- A. Instacoustic B40 acoustic cradle & batten floor system
- B. Terrain UFH ST 35 tacker panel, installed between cradles
- C. Tacker insulation panel spot bonded to structural floor
- D. Installation to be by approved Terrain Under floor heating installer

2. Pipe work

- A. Pipe work 15mm / 18mm Terrain Polybutylene with integral oxygen barrier, 5 layer extrusion
- B. Pipe work covered by 50 year guarantee - see also BBA and WRAS approvals
- C. Each pipe work circuit shall be laid in a continuous pipe length, no joints permitted
- D. Each circuit(s) shall be sized and outputs reflect the heat loss of each heated zone
- E. Dedicated circuit(s) for each heated zone
- F. Under floor heating pipe work within the floor of each zone shall typically be spaced at 200mm centres.
- G. Both flow and return for each circuit shall terminate at the manifold locations
- H. Pipe turning from the floor and rising to the manifold shall have a bend former fitted to avoid pipe over bending and maintaining correct radius
- I. Heating pipe work not installed into a panel must be covered by our supplied conduit to limit heat transfer.
- J. Any transit pipe work not in panel must have insulation placed beneath

3. Manifolds

- A. Manifold shall be stainless steel multi port to suit design and application, Manifold data sheet attached.
- B. Manifold Supplied with Isolating Valves, flow temperature adjusting blending valve (flow temperature setting), air vents, drain cocks. Manifold body attached to wall mounting brackets with rubber isolating sleeves
- C. Flow indicators on each port/pipe circuit to enable correct commissioning and visual verification of operation, adjustable flow valves on each circuit.
- D. Manifold Size dependant on number of circuits required for each apartment (See manifold data sheet for dimensions of manifold)

4. Pump Sets

- A. Pre assembled with Blending Valve. Water Blending adjustment from 35-60 Deg C
- B. Pump to be Grundfoss Circulation Pump or similar
- C. Option for Alpha 2L energy efficient pump available on request Class A energy

New Build - Acoustic Batten Under Floor Heating Solution

5. Controls

- A. Actuators, wiring centres and thermostats will be supplied as 230v system
- B. Thermostats within public areas to be anti tamper type, Non Public areas to receive LCD 7 day time, temperature, set back, frost protection and holiday mode
- C. Switchable PI and Anti Pump Brake features as per Terrain FH.STAT.1
- D. Controls to be installed for each heated zone (room) allowing individual control of functions as stated above (not on public areas)
- E. Wiring Centre Master and Slave to be located adjacent to manifold(s) locations.
- F. All electrical wiring by controls specialist/electrical contractor

6. Standards / Approvals

- A. Manufacturing Quality Assurance in accordance with BS EN ISO 9001-2000
- B. Polypipe Polybutylene barrier pipe are covered by BBA Certificate No. 00/3699
- C. British Gas has accepted the Polypipe Class S Polybutylene pipe system as being acceptable for open vented and sealed central heating systems and is eligible for acceptance onto Three Star Central Heating System Cover
- D. British Standard Class S rated BS7291 Part 1 and Kitemark license number 38148 to BS7291 part 2 Listed in the WRAS Water Fittings and Materials Directory KIWA/KOMO Certificate numbers K14341,14342 and 14343
- E. Polypipe is a member of the Polybutylene Piping Systems Association, which is a recognised association of companies whose aim is to promote the features, benefits and best practice installation techniques of polybutylene pipe systems.
- F. UHMA - Polypipe are full members of the Under floor Heating Manufacturers Association.
- G. Polypipe have been awarded the **Carbon Trust Standard**, awarded to organisations that have measured, managed and genuinely reduced their carbon emissions.

Floor Finishes

Please note that the thermal efficiency of the floor system will be dependant upon the type of floor finishes laid. The following points should be considered when choosing floor finishes:

Carpet

It is advisable not to use a carpet that has a TOG rating of over 2, this should also include the underlay being used. Normally 80% wool type carpets provide a lower TOG rating or thermal resistance than artificial man-made fibres.

Ceramic Tiles

Ceramic tiles transfer the heat well. Please refer to the InstaCoustic adhesive specification which refers to the type of anti fracture mat and flexible adhesive for ceramic tiles.

Wood Floors

We would suggest that a 8mm to 14mm engineered hardwood system should be used. This is important because the thickness/density of the hardwood floor directly affects the thermal resistance.