

## ACOUSTIC WALLING SYSTEM AF28

The AF28 walling system is primarily used as economical anti-flanking systems that prevents noise transmission from floors to walls.

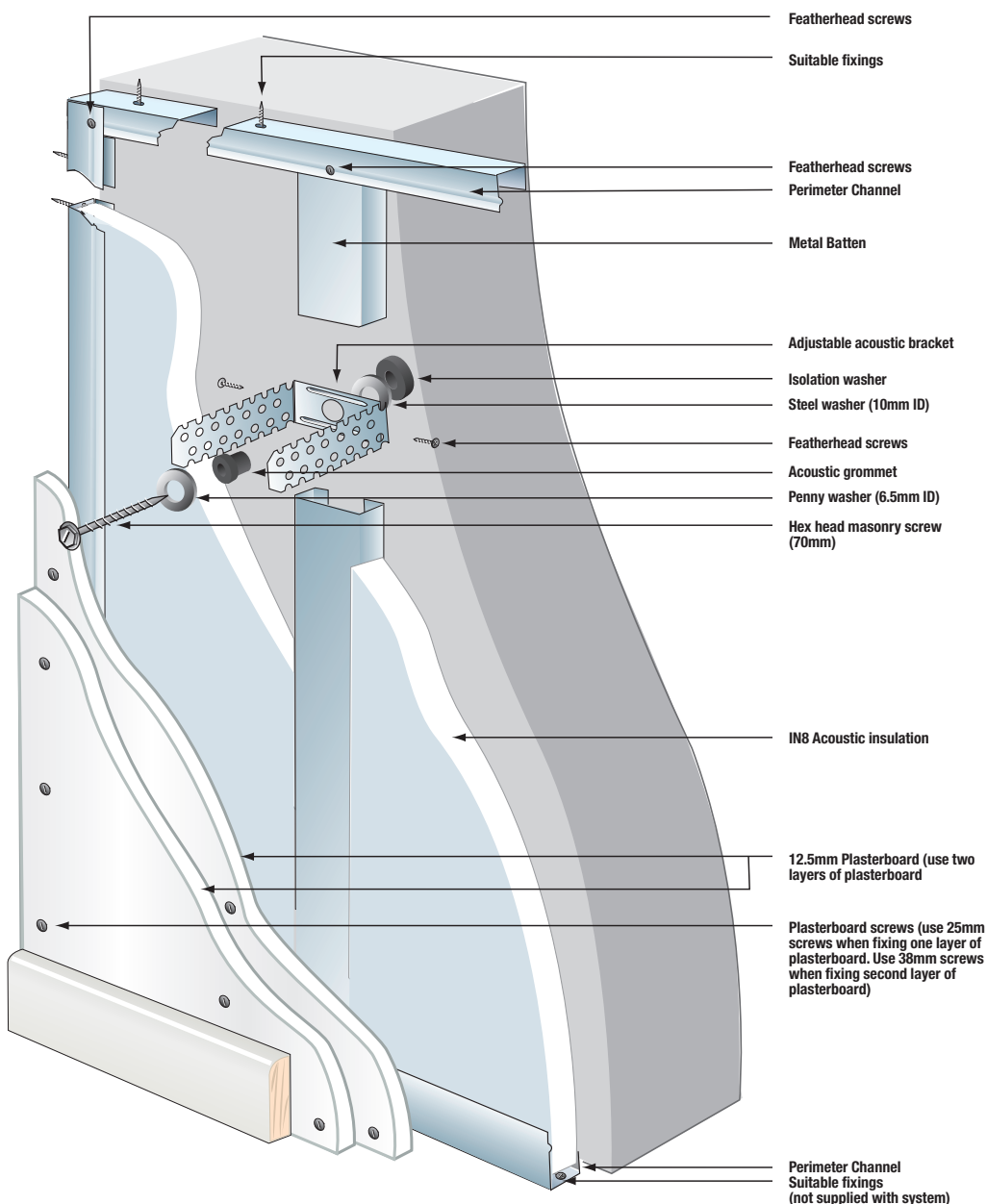

## COMPONENTS



Isolation washer



Adjustable Acoustic Bracket (supplied flat)



Steel washer (10mm ID)



Penny Washer (6.5mm ID)



Acoustic grommet



Fixing screws



Metal Batten  
3.0m lengths

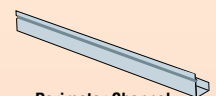

Perimeter Channel  
3.0m lengths

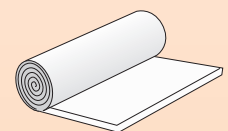

IN8 Acoustic insulation  
0.58m x 20.0m roll

**InstaCoustic**

THE SOUND SOLUTION

Tel: 0118 973 9560 Fax: 0118 973 9547

Email: sales@instacoustic.co.uk

www.instacoustic.co.uk

Insta House, Ivanhoe Road

Hogwood Business Park, Finchampstead

Wokingham, Berks RG40 4PZ

## ACOUSTIC WALLING SYSTEM AF28

**STEP 1** PERIMETER CHANNEL fixed to wall, floor and ceiling with fixings at 600mm centres. (The distance from the wall to be treated to the perimeter batten is dependent upon the overall system depth required).

**STEP 2** ACOUSTIC BRACKETS, complete with isolation washer, steel washer and acoustic grommet screwed to the wall at 600mm centres horizontally, and ideally at 800mm centres vertically. Vertical spacings may be exceeded but should not be more than 900mm. Fix to wall with tapcon or suitable fixings. (Acoustic brackets are supplied flat).

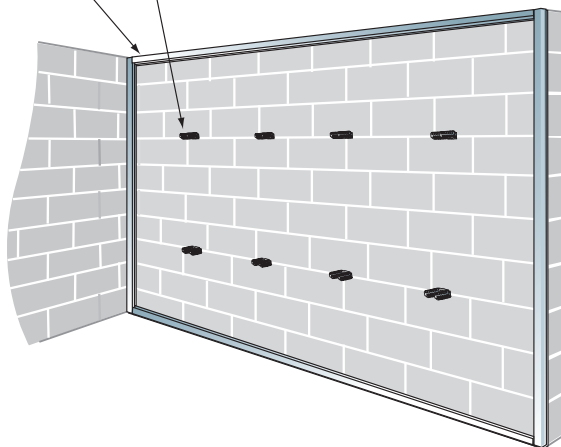

**STEP 3** METAL BATTENS cut to length to fit within and between the top and bottom Perimeter Channels. Position the battens in line with the acoustic hangers and screw through the perimeter channel into the battens with featherhead screws top and bottom.

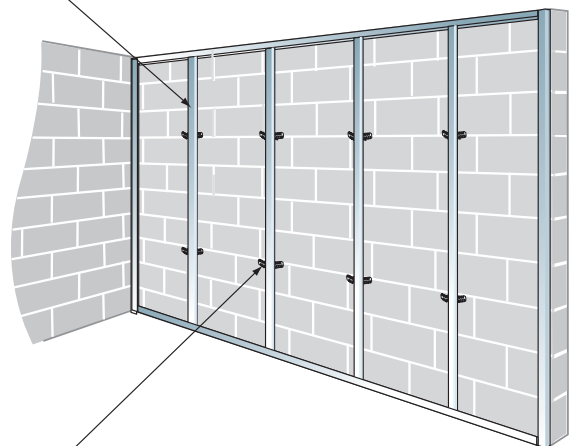

**STEP 4** ACOUSTIC BRACKET LEGS bent forward around the sides of the metal battens and each leg screwed to the metal batten with featherhead screws. Cut off or bend back the acoustic bracket legs to suit.

**STEP 5** IN8 ACOUSTIC INSULATION positioned between the Battens. Ensure that the first row of insulation is tucked into the perimeter channel and trapped behind the metal batten.

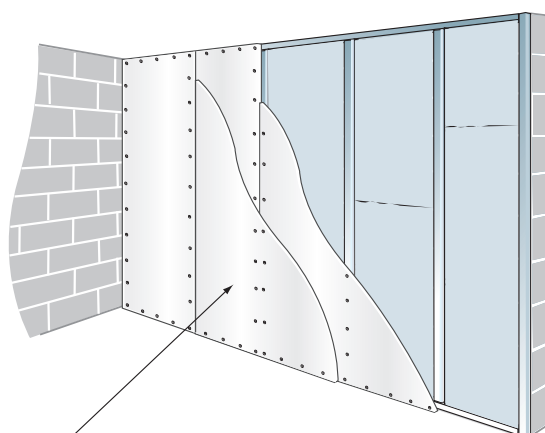
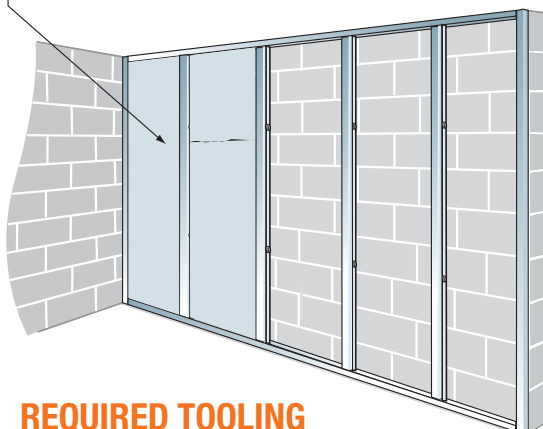

**STEP 6** Plasterboard cut to size and fixed by screwing to the metal battens and perimeter channel at 300 centres. Where the plasterboard joins on a batten, ensure that the joins occur on its centre line. Use 25mm plasterboard screws to fix the first layer of plasterboard. When fixing a second layer of plasterboard, ensure that the joins are staggered with those of the first layer. Use 38mm plasterboard screws to fix the second layer of plasterboard. Seal the finished wall system at its edge with InstaCoustic sealant."

### REQUIRED TOOLING

- STEPS/SCAFFOLDING
- HAMMER DRILL
- BATTERY DRILL
- PENCIL
- UTILITY KNIFE
- TAPE MEASURE

# ACOUSTIC WALLING SYSTEM AF28

Detail showing internal and external corner assembly

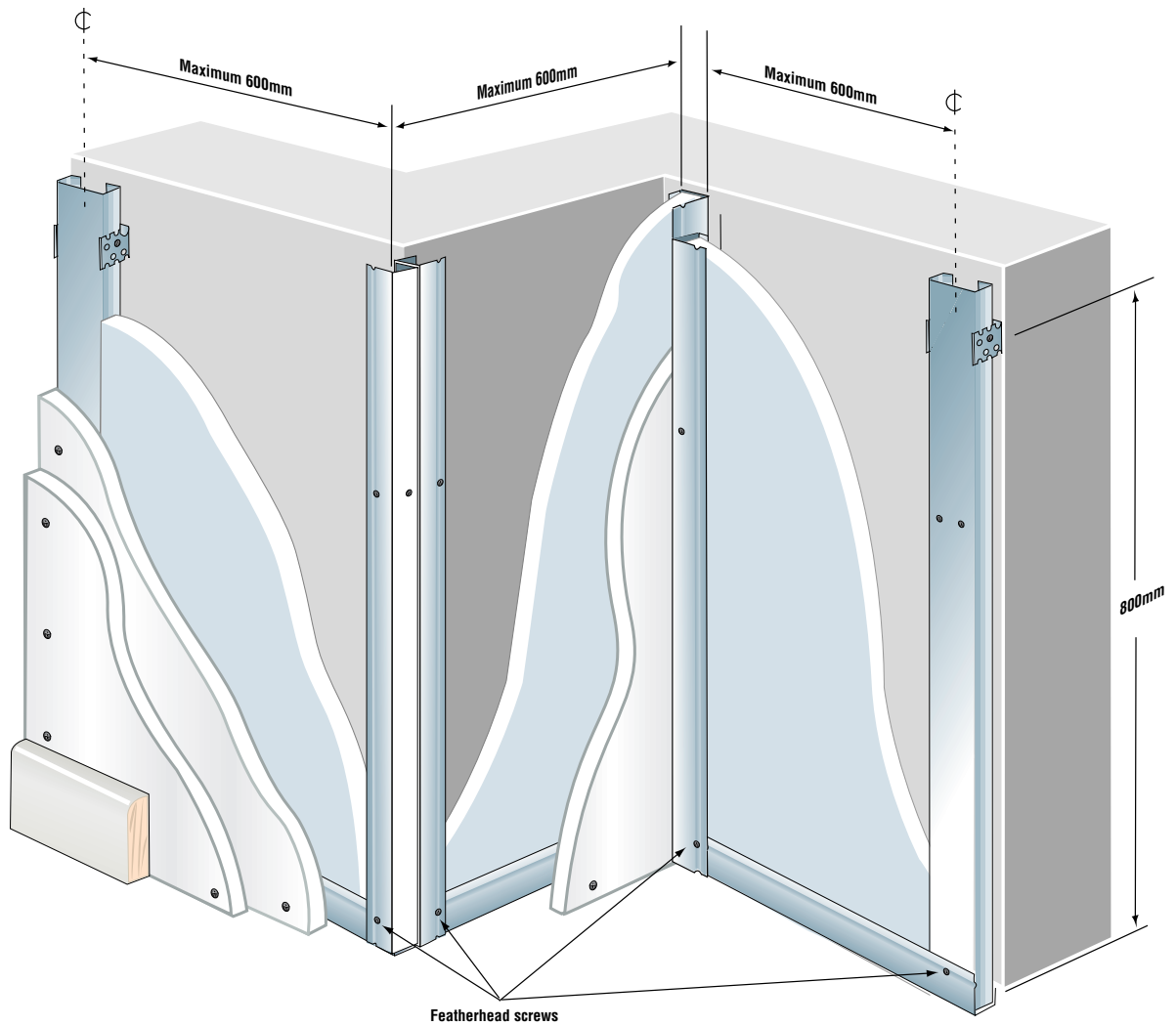

External corner assembly

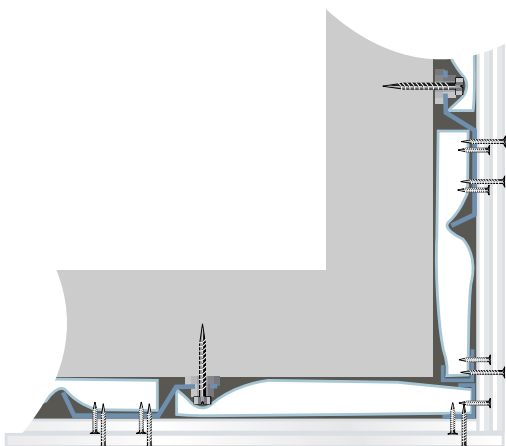

Internal corner assembly

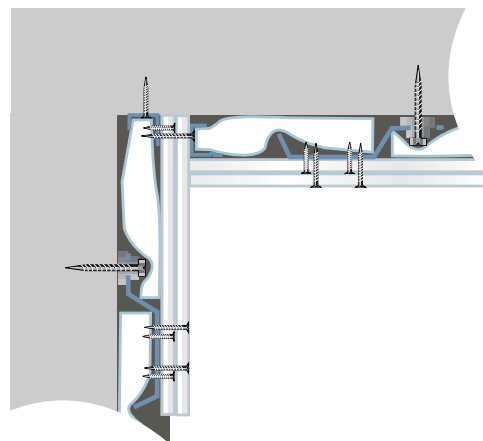

# walls

## ACOUSTIC WALLING SYSTEM **AF28**

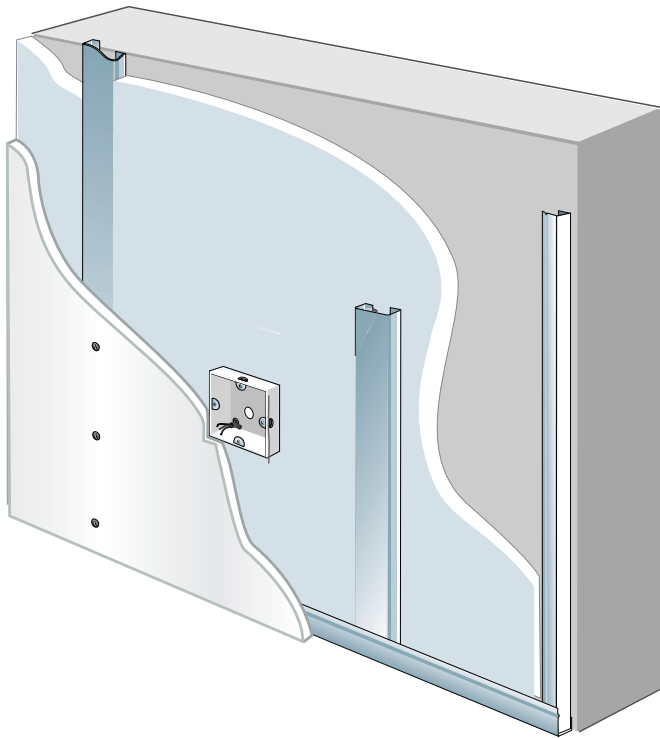

**NOTE:** If electrical boxes need to be fitted within the AF28 acoustic wall system it is critical that these boxes do not come into contact with the structural wall being treated. Any contact with the existing structural wall will create points of contact providing a direct transmission path for sound. Therefore in all cases electrical points must be fitted within the new acoustic wall skin by means of boxes that are designed specifically to clip into the plasterboard skin. Cut an appropriate aperture in the plasterboard wall panel as shown in the adjoining diagram and install the electrical box.